

NOTE:
Please read all instructions
carefully before using this
product

Table of Contents

Safety Notice

Important Assembly
Information

Care and Maintenance

Parts List

Warranty

Ordering Parts

Model
SM-7409

Retain This
Manual for
Reference

190701

**OWNER'S
MANUAL**

MARCY®

MARCY PRO SMITH MACHINE SM-7409

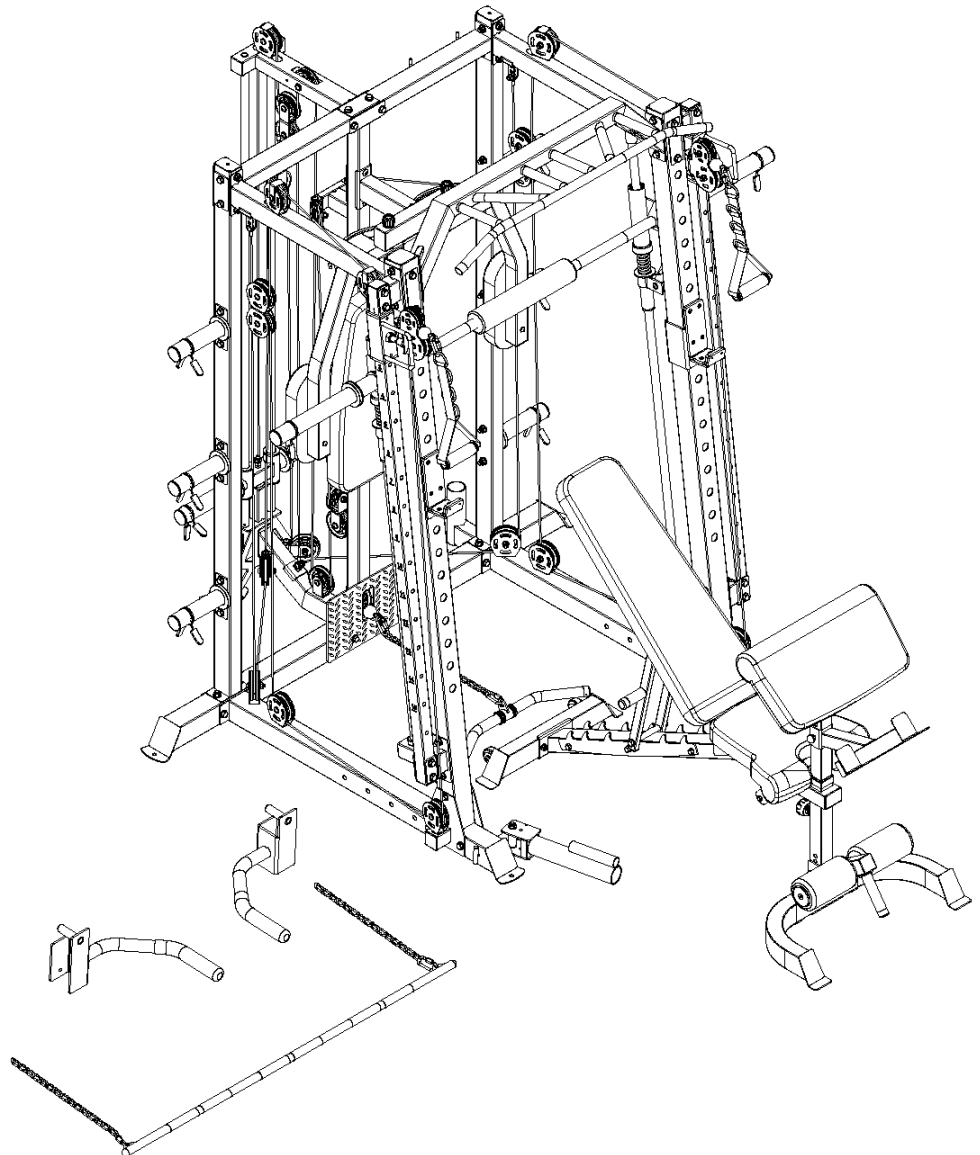

IMPORTANT: Please read this manual before commencing
assembly of this product.

IMPEX® INC.

2801 S. Towne Ave, Pomona, CA 91766

Tel: 800-999-8899

www.marcypro.com

TABLE OF CONTENTS

BEFORE YOU BEGIN	1
IMPORTANT SAFETY NOTICES	2
EXERCISE GUIDELINES	3
WARNING LABEL PLACEMENT	5
FREE AND TRAINING AREA	6
IMPORTANT ASSEMBLY INFORMATION	7
CABLE ASSEMBLY INSTRUCTION	8
WEIGHT CAPACITY AND DIMENSION	11
CARE AND MAINTANENCE	11
OPERATING NOTES	12
WEIGHT RESISTANCE CHART	13
PARTS LIST	14
EXPLODED DIAGRAM - CAGE	20
EXPLODED DIAGRAM - BENCH	22
WARRANTY	23
ORDERING PARTS	23

BEFORE YOU BEGIN

Thank you for selecting MARCY SMITH MACHINE SM-7409 by IMPEX® INC. For your safety and benefit, read this manual carefully before using the equipment. As a manufacturer, we are committed to providing you with complete customer satisfaction. If you have any questions, or find there are missing or damaged parts, we guarantee you complete satisfaction through direct assistance from our factory. To avoid unnecessary delays, *please call our TOLL-FREE customer service number*. Our Customer Service Agents will provide immediate assistance.

Toll-Free Customer Service Number

1-800-999-8899

Mon. – Fri. 9 a.m. – 5 p.m. PST

www.marcypro.com

support@impex-fitness.com

IMPORTANT SAFETY NOTICE

This exercise equipment is built for optimum safety. However, certain precautions apply whenever you operate a piece of exercise equipment. Be sure to read the entire manual before you assemble or operate your equipment. In particular, note the following safety precautions:

1. **Keep children and pets away from the equipment at all times. DO NOT leave children unattended in the same room with the equipment.**
2. Only one person at a time should use the equipment.
3. If the user experiences dizziness, nausea, chest pain, or any other abnormal symptoms, STOP the workout at once. CONSULT A PHYSICIAN IMMEDIATELY.
4. Position the equipment on a clear, leveled surface. DO NOT use the equipment near water or outdoors.
5. Keep hands away from all moving parts.
6. Always wear appropriate workout clothing when exercising. DO NOT wear robes or other clothing that could become caught in the equipment. Running or aerobic shoes are also required when using the equipment.
7. Use the equipment only for its intended use as described in this manual. DO NOT use attachments not recommended by the manufacturer.
8. Do not place any sharp object around the equipment.
9. Disabled persons should not use the equipment.
10. Before using the equipment to exercise, always do stretching exercises to properly warm up.
11. Never operate the equipment if the equipment is not functioning properly.
12. A spotter is recommended during exercise.
13. **This equipment is designed and intended for home and consumer use only, not for commercial use.**

WARNING: BEFORE BEGINNING ANY EXERCISE PROGRAM, CONSULT YOUR PHYSICIAN. THIS IS ESPECIALLY IMPORTANT FOR INDIVIDUALS OVER THE AGE OF 35 OR PERSONS WITH PRE-EXISTING HEALTH PROBLEMS. READ ALL INSTRUCTIONS BEFORE USING ANY FITNESS EQUIPMENT. IMPEX INC. ASSUMES NO RESPONSIBILITY FOR PERSONAL INJURY OR PROPERTY DAMAGE SUSTAINED BY OR THROUGH THE USE OF THIS PRODUCT.

SAVE THESE INSTRUCTIONS.

EXERCISE GUIDELINES

Building Muscle and Gaining Weight

Unlike aerobic exercise, which emphasizes endurance training, anaerobic exercise focuses on strength training. A gradual weight gain can occur while building the size and strength of muscles. While developing muscle mass, your body adapts to the stress placed upon it. You can modify your diet to include foods such as meat, fish and vegetables. These foods help muscles recover and replenish important nutrients after a strenuous workout.

Muscle Strength and Endurance

To achieve the greatest benefit from exercise, it is important to develop an exercise program that allows you to work all of the major muscle groups equally.

To increase muscle strength, follow this principle:

Increasing resistance and maintaining the number of repetitions of an exercise results in increased muscle strength.

To tone your body, follow this principle: Decreasing resistance plus increasing the number of repetitions of an exercise results in increased body tone.

Once you feel comfortable with an exercise, you can change the resistance, the number of repetitions, or the speed at which you do the exercise. It is not necessary to change all three variables. For example, let's say that you are training at 23 kg (50 lb.) and performing the exercise 10 times in 3 minutes. When this becomes too easy, you may decide to move up to lifting 27 kg (60 lb.) for the same number of repetitions in the same amount of time. Lifting more weights fewer times most often develops muscle strength. To gain both muscle strength and endurance, it is recommended that you perform each exercise 15 to 20 reps per set.

Training Intensity

How hard you begin to train depends on your overall level of fitness. The soreness you experienced can be lessened by decreasing the load you place on your muscles and by performing fewer sets. To avoid injury, you should gradually work into an exercise program and set the load to your individual fitness level. The load should increase as your fitness level increases.

Muscle soreness is common, especially when you first start exercising. If you are painfully sore for a long time, it may be time to change your program. Eventually, your muscle system will become accustomed to the stress and strain placed on it.

Beginning a Strength Building Program

Warming Up

To begin strength training, it is important to stretch and perform light exercise for 5 to 10 minutes. This helps prepare the body for more strenuous exercise by increasing circulation, raising your body temperature and developing more oxygen to your muscles.

Workout

For each workout, to keep in mind that muscle soreness that lasts for a long period is not desirable and may mean that injury has occurred.

Cool Down

At the end of each workout, perform slow stretching exercises for 5 to 10 minutes. Ease into each stretch only going as far as you can. This stage allows your muscles to wind down after training.

To provide a total workout program it is also recommended that 2 to 3 days of aerobic exercise is performed in addition to the strength training.

Drinking Water

For the body to function properly, it must be properly hydrated. If you are exercising, you should increase your fluid intake. The reason for this is that the water you take in will leave your system through the sweating mechanism that cools your body during exercise. The water you lose through exercise must be replaced so that the muscles can recover properly.

Rest Day

Although you may not feel like doing it, taking a rest day at least once a week is important because it gives your body a chance to heal it self. Continuously working your muscles will result in over- training, which will not benefit you in the long run.

WARNING LABEL PLACEMENT

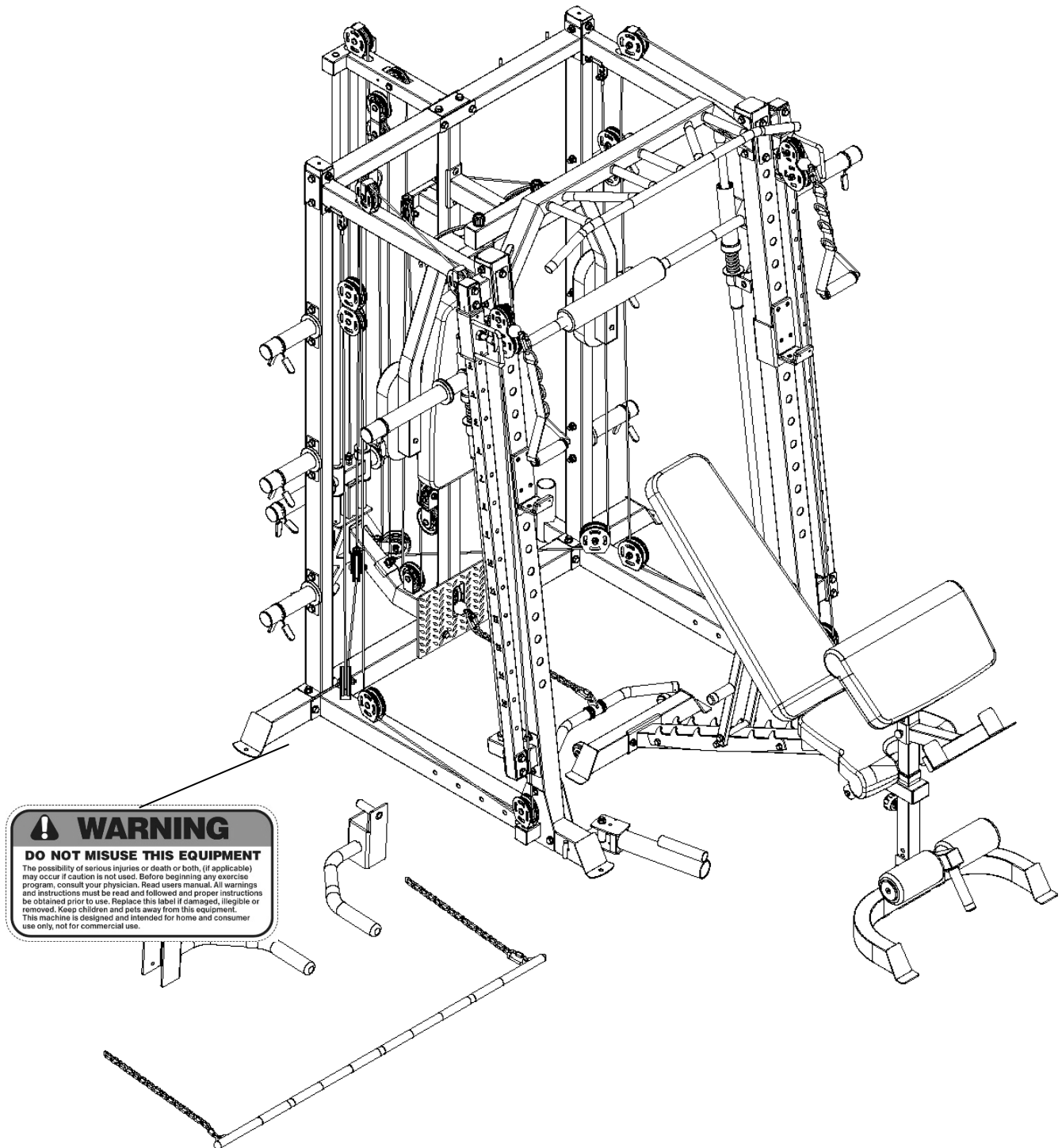

The warning labels shown here have been placed on the Cross Brace, Rear Stabilizer, and Upper Frame. If the labels are missing or illegible, please call customer service at 1-800-999-8899 for replacements. Apply the labels in the location shown.

FREE AND TRAINING AREA

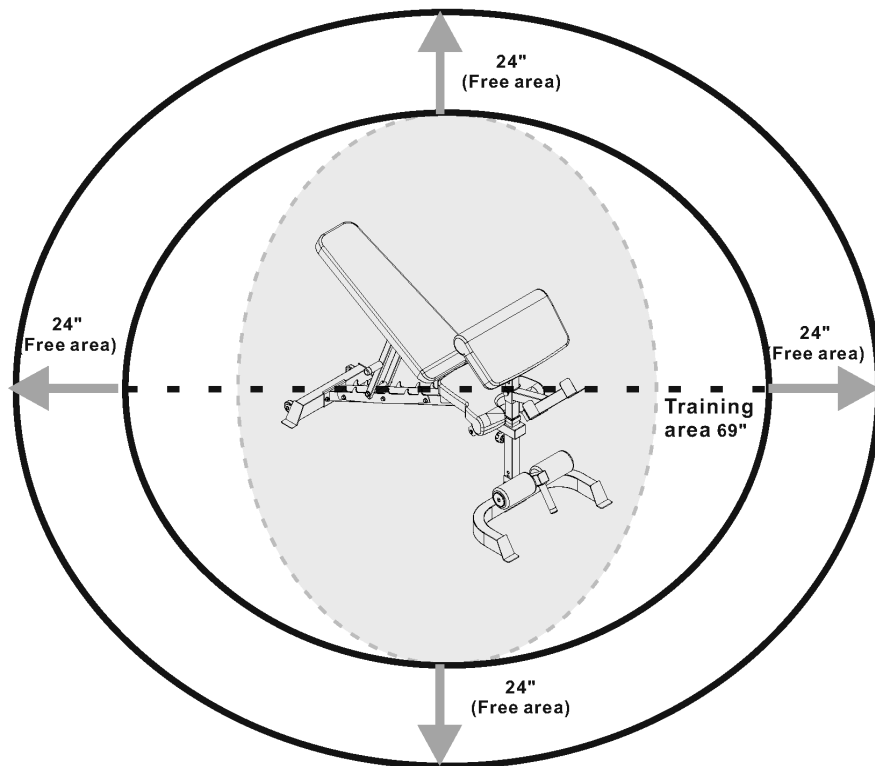
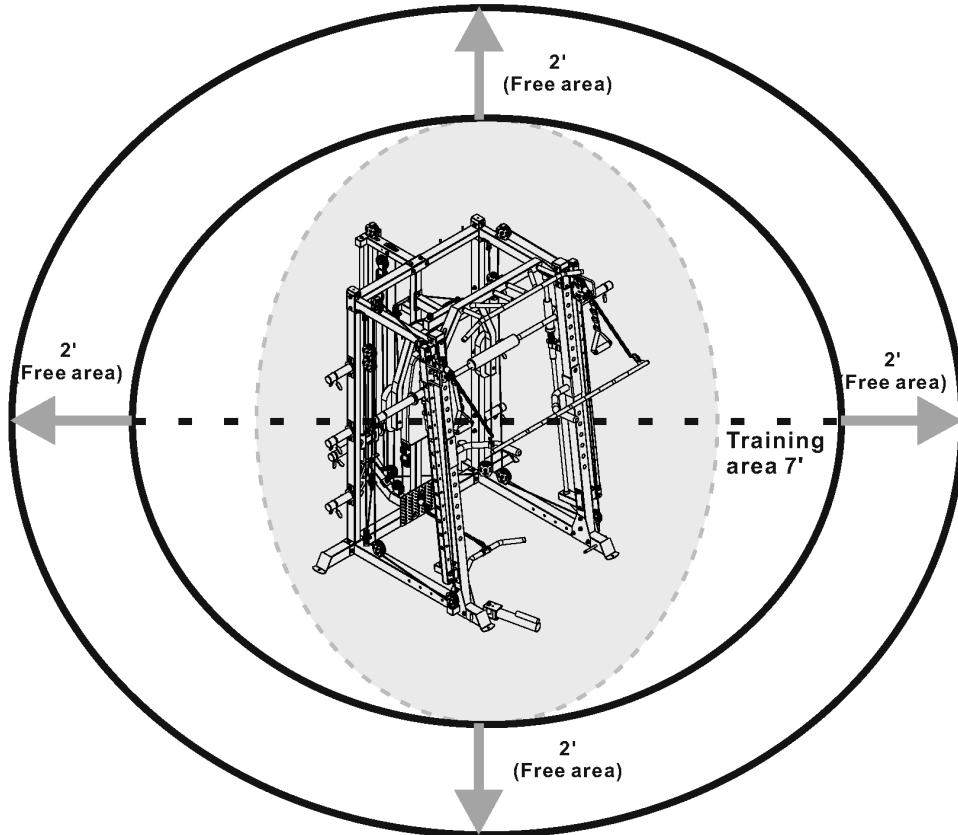

IMPORTANT ASSEMBLY INFORMATION

- ❖ Tools required for assembling the bench: Two adjustable Wrenches and Allen wrenches.
- ❖ NOTE: It is strongly recommended that this equipment be assembled by two or more people to avoid possible injury.
- ❖ Ensure **Carriage Bolts** are inserted through the **SQUARE holes** on components that need to be assembled. Attach washer only to end of the Carriage Bolt.
- ❖ Use **Allen Bolts or Hex Bolts** inserted through the **ROUND hole** on components that need to be assembled.
- ❖ Always wait until all bolts are assembled onto the bench before tightening the bolts. Do not tighten each bolt right after it is installed

Fasten Nuts and Bolts

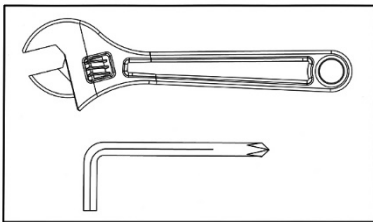

Securely tighten all nuts and bolts after all components have been assembled in current and previous steps.
NOTE: Do not over-tighten any component with pivoting function.
Make sure all pivoting components are able to move freely.

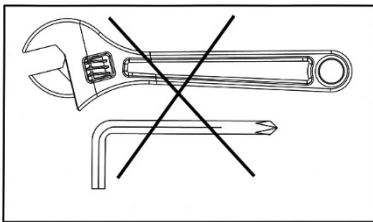

Do not tighten all nuts and bolts in this step.

- ❖ **Inspect and ensure all bolts and Nuts are fastened after the equipment is completely assembled.**

Assemble with correct Hardware Pack

- ❖ **Only use the hardware packs marked “For Smith Machine” to assemble Smith Machine.**
- ❖ **Only use the hardware packs marked “For Bench” to assemble Bench.**

Tools

Tools required for assembling this equipment: Allen Wrenches (provided by manufacturer), and Adjustable Wrench, or Socket Wrench, or Ratchet Wrench.

NOTE: It is strongly recommended that this machine be assembled and moved by two or more people to avoid possible injury.

SMITH MACHINE CABLE ASSEMBLY INSTRUCTION

Cable Loop Diagram

Please follow the direction of the arrows when installing the cables to ensure proper assembly.

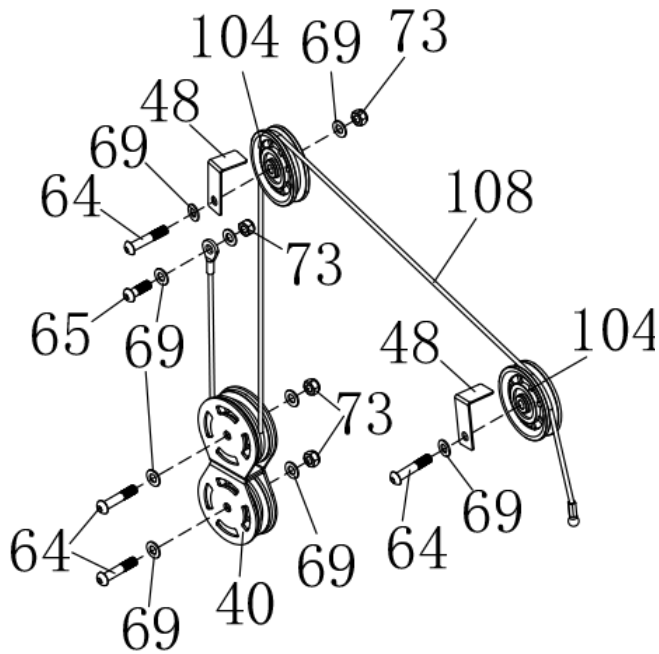

Upper Left Cable Pulley

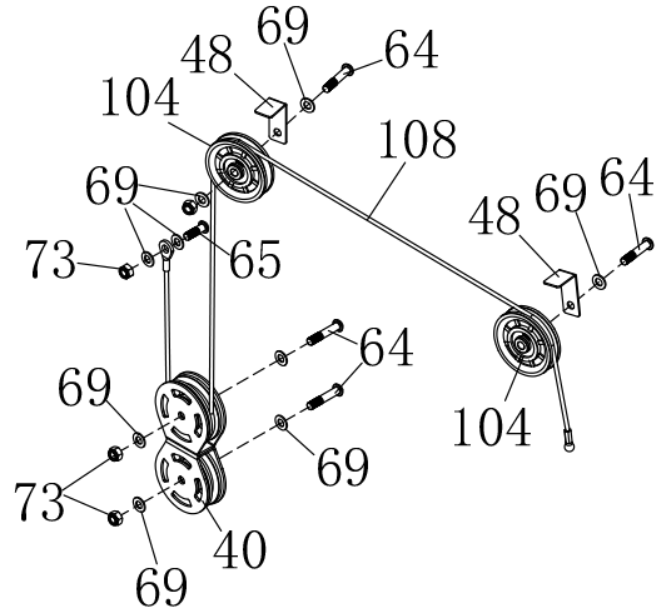

Upper Right Cable Pulley

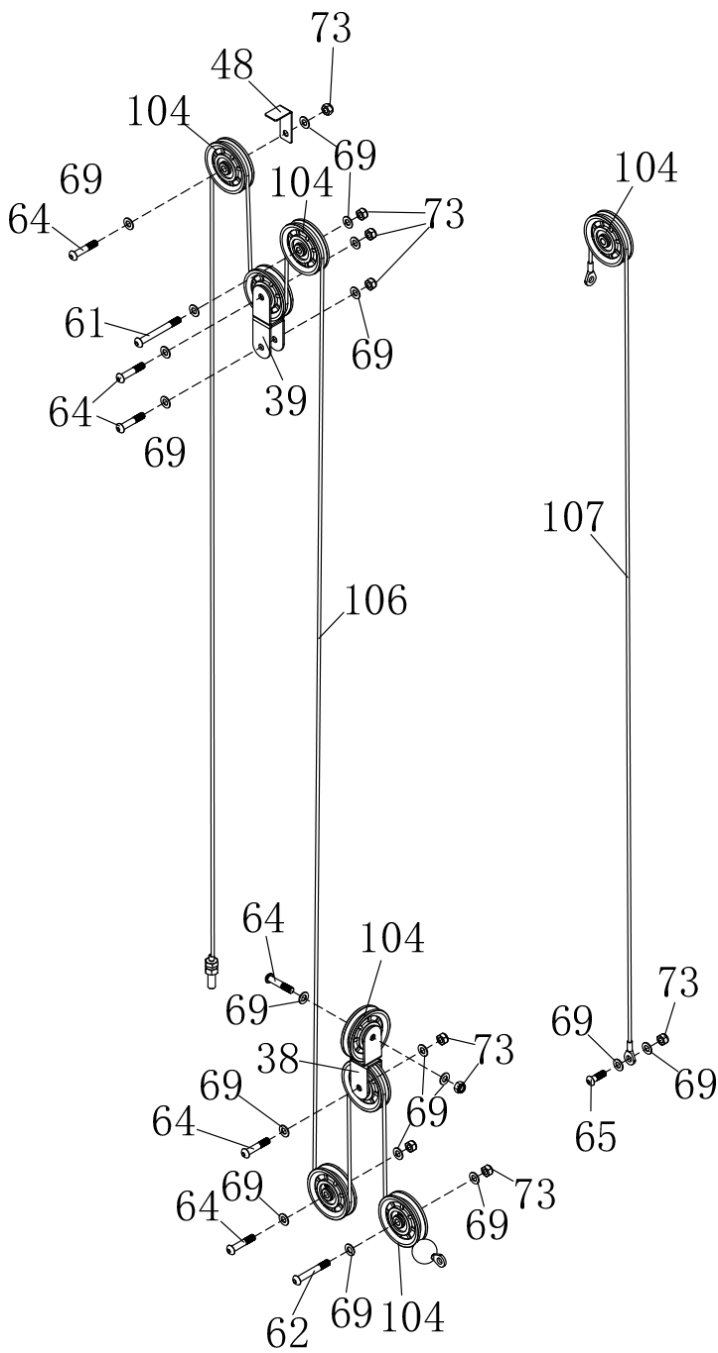

Weight Trolley (#106) and Connector
(#107) Cable

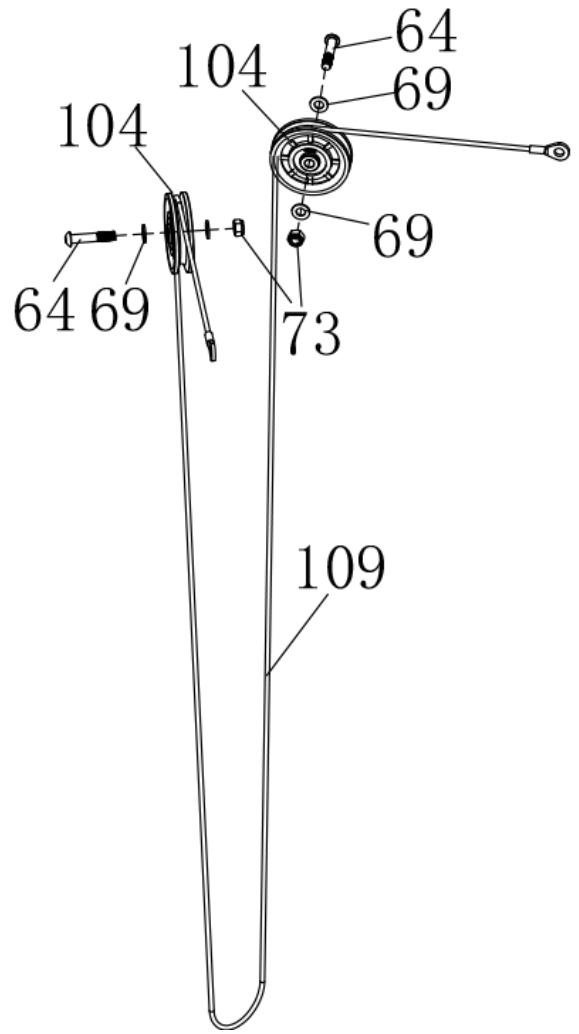

Butterfly Cable

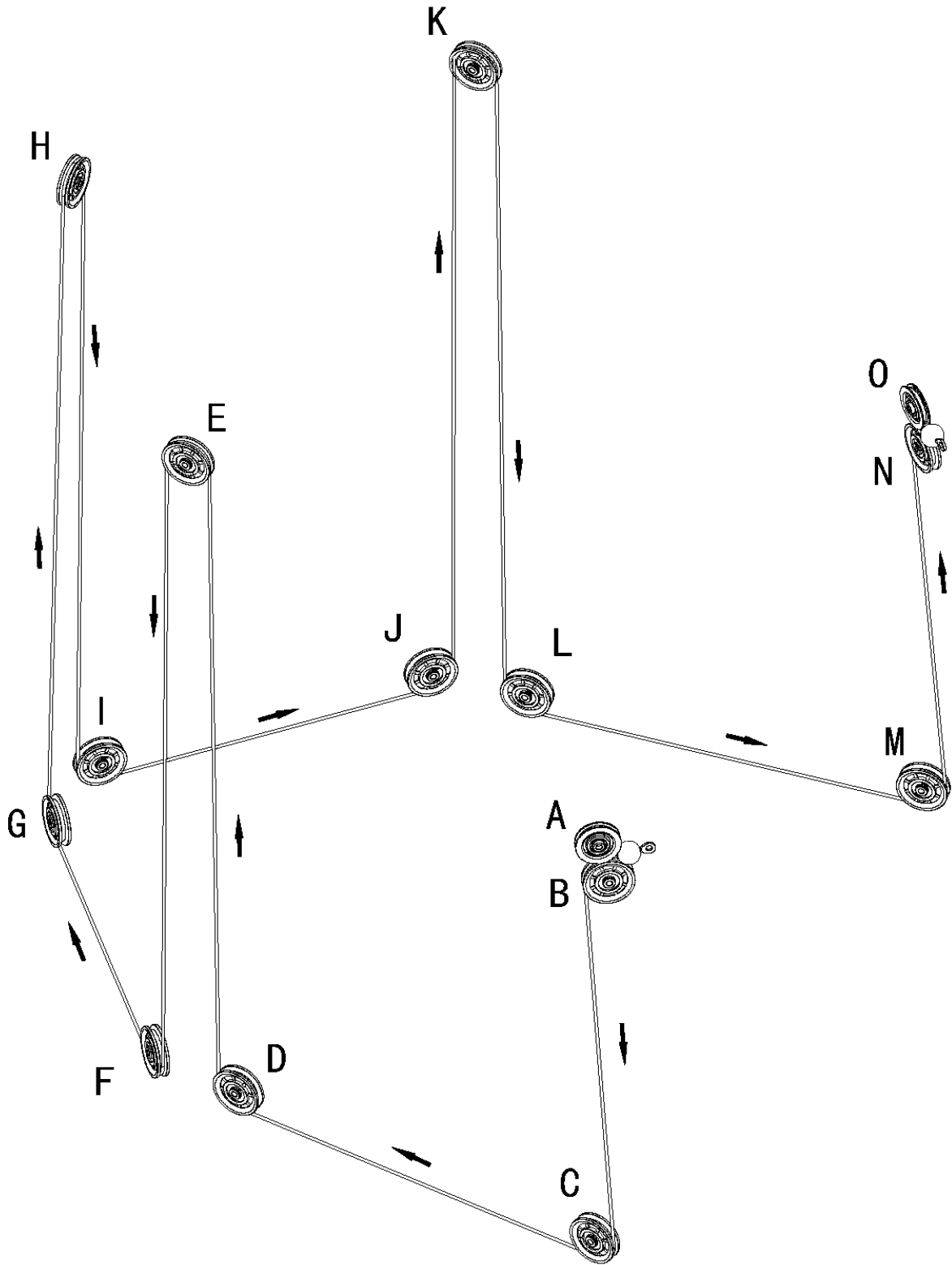

Cross Cable Routing

WEIGHT CAPACITY AND DIMENSION

1. Maximum user weight: 300 lbs.
2. Maximum weight on Sliding Weight Trolley (#13): 300 lbs (150lbs on each side)
3. Maximum weight on storage Weight Post (#17): 100 lbs
4. Maximum weight on Bar Catch: 300 lbs
5. Maximum weight on Weight Bar (#18): 300 lbs
6. Maximum weight on Bench: 600lbs (including user weights)
7. Cage assembled dimensions: 83.5"x67.8"x86.2"
8. Bench assembled dimensions: 63"x26.4"x53.9".

CARE AND MAINTENANCE

1. Lubricate moving parts with WD-40 or light oil periodically.
2. Inspect and tighten all parts before using the equipment.
3. The equipment can be cleaned using a damp cloth and mild non-abrasive detergent.
DO NOT use solvents.
4. Examine the equipment regularly for signs of damage or wear.
5. Replace any defective components immediately and/or keep the equipment out of use until repair.
6. **Failure to examine regularly may affect the safety level of the equipment.**

OPERATION NOTES

This equipment should be placed on flat surface. The incline or decline of surface should be limited to 3% or less for best performance and safety.

Bench Backrest Adjustment Angles

Backrest adjustment angle ranges from -27° to 76° .

Seat angle adjustment ranges from 0° to 16° .

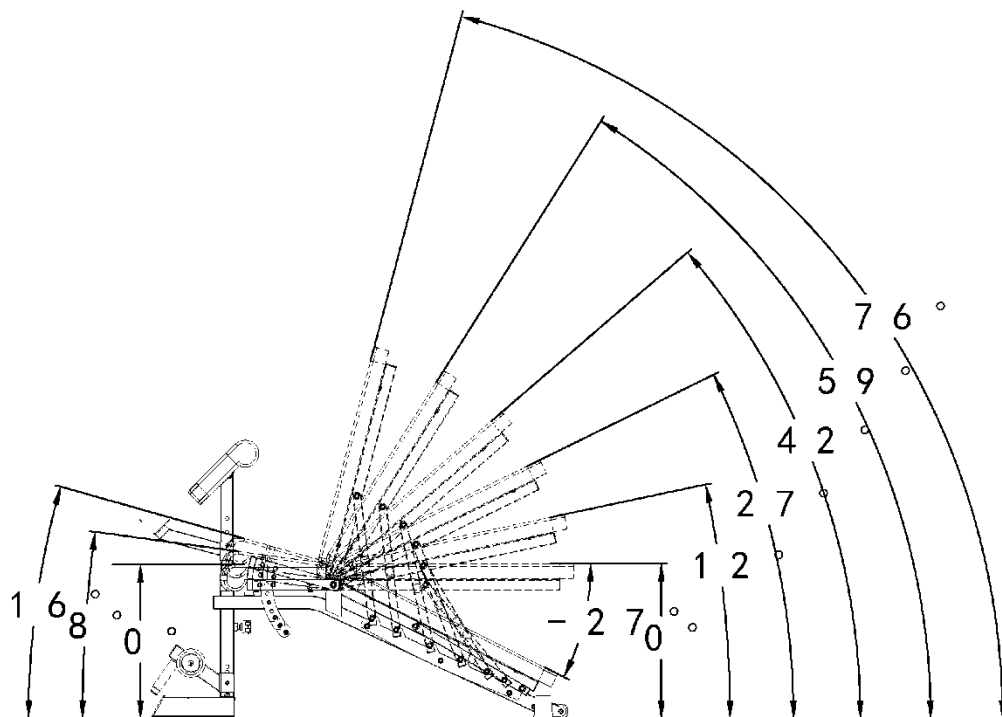

SM-7409 WEIGHT RESISTANCE CHART

WEIGHT RESISTANCE CHART		
Station	Ratio	Example
Low Pulley	100%	10 lb. plate creates 10 lb. resistance.
Butterfly (both arms)	100%	10 lb. plate creates 10 lb. resistance.
Left Cross-Over	50%	10 lb. plate creates 5 lb. resistance.
Right Cross-Over	50%	10 lb. plate creates 5 lb. resistance.

***Numbers are approximate. Actual resistance may vary.**

SM-7409 PARTS LIST

Part #	Description	Size	Qty
1	Rear Base Frame		1
2	Front Vertical Beam		2
3	Left Base Frame		1
4	Right Base Frame		1
5	Rear Upright Frame		2
6	Left Upper Frame		1
7	Right Upper Frame		1
8	Smith Bar Olympic Sleeve		2
9	Double Pulley Assembly		2
10	Storage Post		6
11	Upper Frame Connector		1
12	Lower Frame Connector		1
13	Weight Trolley		1
14	Lifting Sleeve		1
15	Inner Base Frame Bracket		2
16	Bracket	2 ³ / ₈ " × 4 ³ / ₄ "	3
17	Guide Rod		2
18	Weight Bar		1
19	Pulley Rail		2
20	Cable Pulley Assembly		2
21	Butterfly Base		1
22	Butterfly Pulley Beam		1
23	Multi-Grip Pullup Rack		1
24	Upper Cross Brace		1
25	Trolley Base Frame		1
26	Short Bar Sleeve		2
27	Trolley Guide Rod		2
28	Short Bar		1
29	Long Bar		1
30	Upper Rail Bracket		2
31	Rubber Bumper	1 ¹ / ₈ " × 1 ¹ / ₈ "	2

32	Outer Base Frame Bracket		2
33	Base Frame Pulley Bracket		2
34	Safety Catch Hook		2
35	Safety Catch		2
36	Right Butterfly Arm		1
37	Left Butterfly Arm		1
38	Angles Double Floating Pulley Bracket		1
39	Double Floating Pulley Bracket		1
40	Large Double Pulley Bracket		2
41	Adjustable Floating Pulley Bracket		1
42	Swivel Pulley Bracket		4
43	Food plate		1
44	T-Locking Bar		2
45	Swivel Attachment		1
46	Lower Rail Bracket		2
47	Barbell Storage Support		1
48	Cable Retainer		5
49	Guide Rod Sleeve		2
50	Left Dip Handle		1
51	Right Dip Handle		1
52	Landmine Attachment		1
53	Bracket		3
54	Bracket	2" x 3"	7
55	Bracket	2 ³ / ₄ " x 6"	1
56	Carriage Bolt	M10 x 2 ³ / ₄ "	4
57	Hex Bolt	M12 x 4"	26
58	Hex Bolt	M12 x 3 ³ / ₄ "	12
59	Hex Bolt	M12 x 3 ¹ / ₂ "	3
60	Hex Bolt	M12 x 3"	26
61	Allen Bolt	M10 x 3 ¹ / ₂ "	1
62	Allen Bolt	M10 x 2 ³ / ₄ "	1
63	Allen Bolt	M10 x 2 ¹ / ₂ "	6
64	Allen Bolt	M10 x ¹ / ₈ "	29
65	Allen Bolt	M10 x 1 ¹ / ₈ "	4

66	Allen Bolt	M10 × ¾"	8
67	Allen Bolt	M8 × 2½"	6
68	Washer	φ5/8"	30
69	Washer	Φ¾"	98
70	Washer	φ1"	144
71	Allen Screw	M8 × ⅜"	4
72	Allen Screw	M6 × ¼"	2
73	Aircraft Nut	M10	50
74	Aircraft Nut	M12	93
75	End Cap		1
76	Butterfly Base End Cap		2
77	Storage Post End Cap		6
78	Weight Trolley End Cap		2
79	Pullup Rack Handle End Cap		2
80	Pullup Rack End Cap		4
81	Nylon Bushing	φ2"×φ1"	4
82	Pulley Rail End Cap	1 3/4"	4
83	Upper Frame Connector End Cap		3
84	Outer Base Frame Bracket End Cap		4
85	Short Bar Clip		4
86	Weight Trolley Bumper		2
87	Grip		2
88	Grip		2
89	Cable Pulley Assembly End Cap		4
90	Safety Catch Bushing		4
91	Butterfly Base Bumper	2" × 6⅝"	1
92	Allen Bolt	M10 × 1¾"	2
93	Butterfly Base Bushing		4
94	Cable Pulley Assembly Bushing		6
95	Large Swivel Attachment Bushing		2
96	Small Swivel Attachment Bushing		2
97	Phillips Screw	M6 × 5/8"	2

98	Linear Bearing		4
99	C-Clip		4
100	Rivet		8
101	Short Bar End Cap		7
102	Allen Screw	M5	7
103	Small Pulley		2
104	Large Pulley		29
105	Cable Pulley Cable	L=462"	1
106	Weight Trolley Cable	L=189"	1
107	Weight Trolley Connector Cable	L=72"	1
108	Upper Cable Pulley Cable	L=132"	2
109	Butterfly Pulley Cable	L=122	1
110	Triceps Rope		1
111	Backrest Pad		1
112	Butterfly Pad		2
113	Barbell Pad		1
114	Spring Clip	φ2"	10
115	Spring Clip Sleeve		20
116	Spring		2
117	Locking Carabiner Clip		6
118	Chain		3
119	Multi-Wrench		2
120	Olympic Sleeve End Cap		2
121	Locking Pin	φ8 × 1½"	1
122	Locking Cap		2
123	Cable Pulley Locking Pin		2
124	Guide Rod Stopper		2
125	Rubber Bumper	Ø3⅛" × Ø2"	10
126	Adjustable Single Handle		1
127	Ankle Strap		1
128	Hex Bolt	M12 × 3½"	3
129	Left Bar Catch		1

130	Right Bar Catch		1
131	Bar Catch Rubber Bumper	3" x 6 ³ / ₄ "	2
132	Bar Catch Rubber Bumper	1 ⁷ / ₈ " x 2 ³ / ₄ "	2
133	Bar Catch Rubber Bumper	1 ¹ / ₈ " x 2 ³ / ₄ "	2
134	Allen Bolt	M6 x ³ / ₈ "	16
135	Bench Main Frame		1
136	Rear Stabilizer		1
137	Front Stabilizer		2
138	Seat Support		1
139	Backrest Support		1
140	Incline Adjustment Support		2
141	Arm Curl Support		1
142	Arm Curl Rack		1
143	Ankle Hold-Down Support		1
144	Seat Support Adjustment Bracket		2
145	Foam Roller Tube		1
146	Incline Adjustment Base		2
147	Hex Bolt	M12 x 6 ¹ / ₄ "	1
148	Hex Bolt	M12 x 6"	2
149	Hex Bolt	M10 x 3 ³ / ₄ "	3
150	Carriage Bolt	M10 x 3 ¹ / ₂ "	2
151	Rubber Bumper	1 ¹ / ₂ " x 1 ¹ / ₂ "	2
152	Hex Bolt	M8 x 4"	1
153	Hex Bolt	M8 x 2 ¹ / ₈ "	4
154	Hex Bolt	M8 x 1 ³ / ₈ "	4
155	Hex Bolt	M8 x ³ / ₄ "	6
156	Aircraft Nut	M8	5+2
157	Allen Bolt	M10 x 1 ¹ / ₈ "	2
158	Backrest Support End Cap		1
159	Arm Curl Rack End Cap		1
160	Seat Support End Cap		4
161	Incline Adjustment Support End Cap		2

162	Arm Curl Support Sleeve		1
163	Transport Wheel	$\phi 2''$	2
164	Grip		1
165	Grip		2
166	Allen Bolt	$M8 \times 1\frac{1}{4}''$	2
167	Back Rest Pad		1
168	Seat Pad		1
169	Arm Curl Pad		1
170	Foam Roller		2
171	Tube	$\phi\frac{5}{8}'' \times \phi\frac{3}{8}'' \times 3\frac{1}{8}''$	1
172	Tube	$\phi\frac{5}{8}'' \times \phi\frac{1}{2}'' \times 3\frac{5}{8}''$	1
173	Quick Release Knob		1
174	Locking Pin	$\Phi\frac{1}{2}'' \times 3\frac{3}{8}'' \times M10$	2
175	Locking Pin	$\Phi\frac{1}{2}'' \times 5'' \times M10$	1
176	Locking Pin End Cap	M8	3
177	Foam Roller End Cap		2

SM-7409 CAGE EXPLODED DIAGRAM

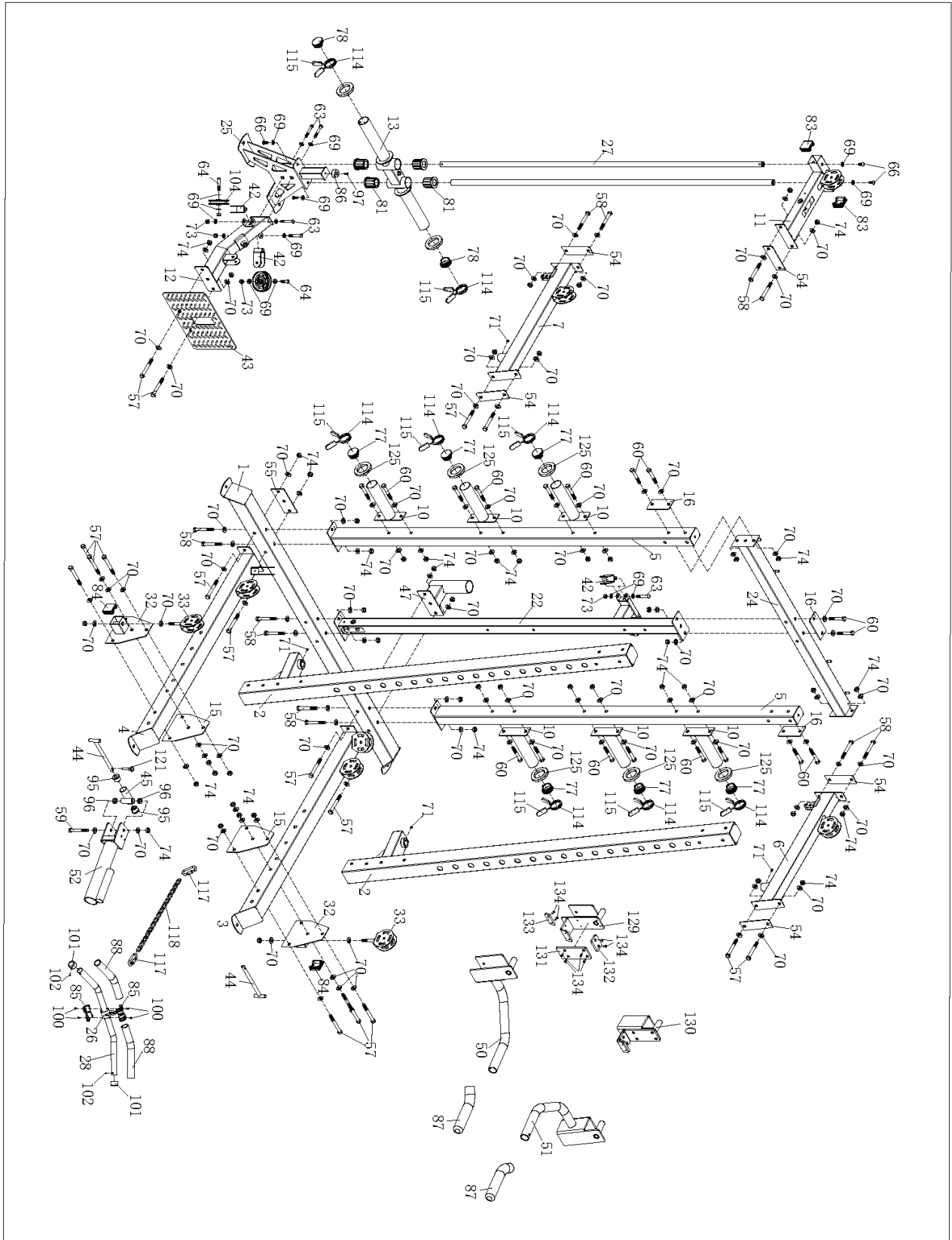

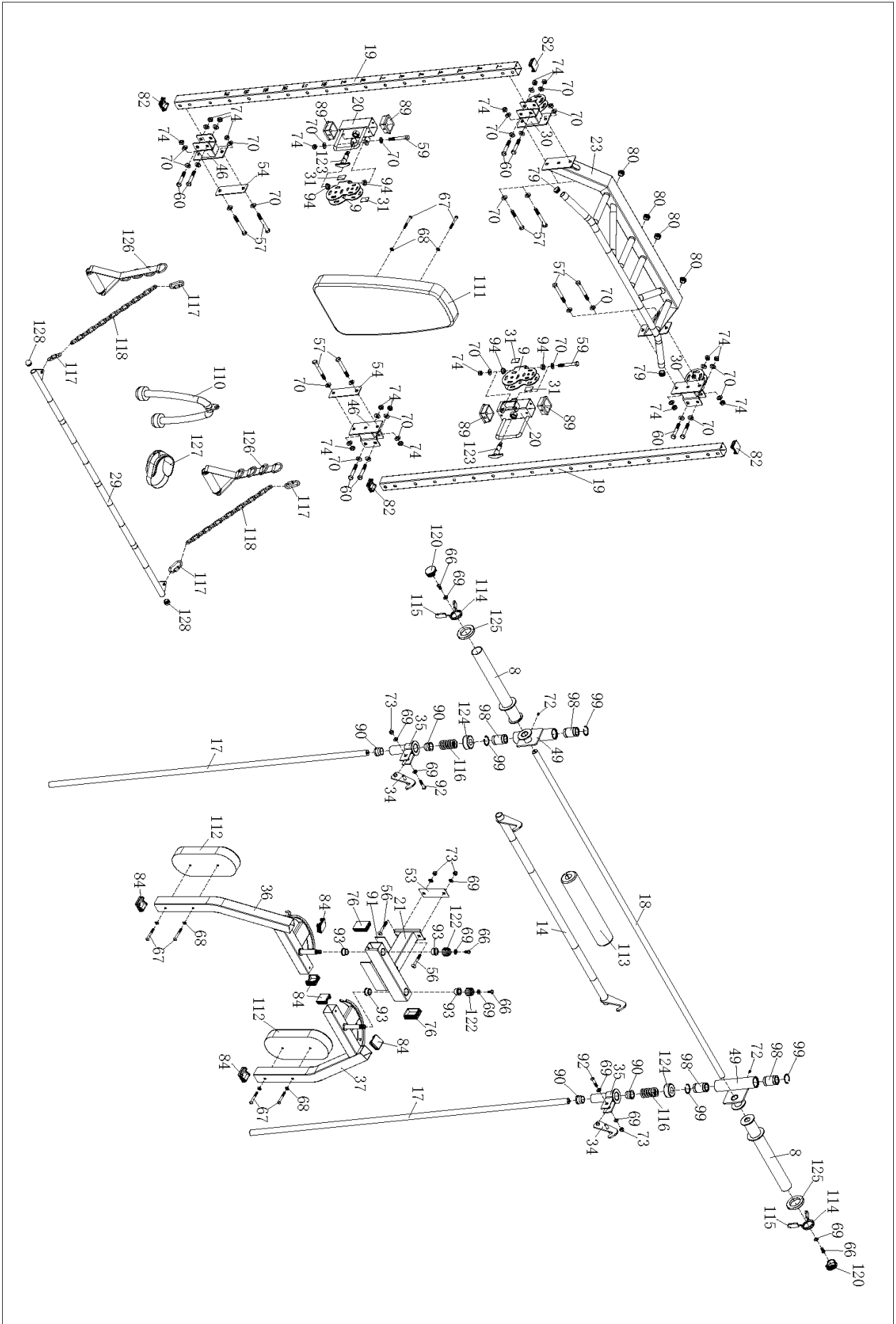

SM-7409 BENCH EXPLODED DIAGRAM

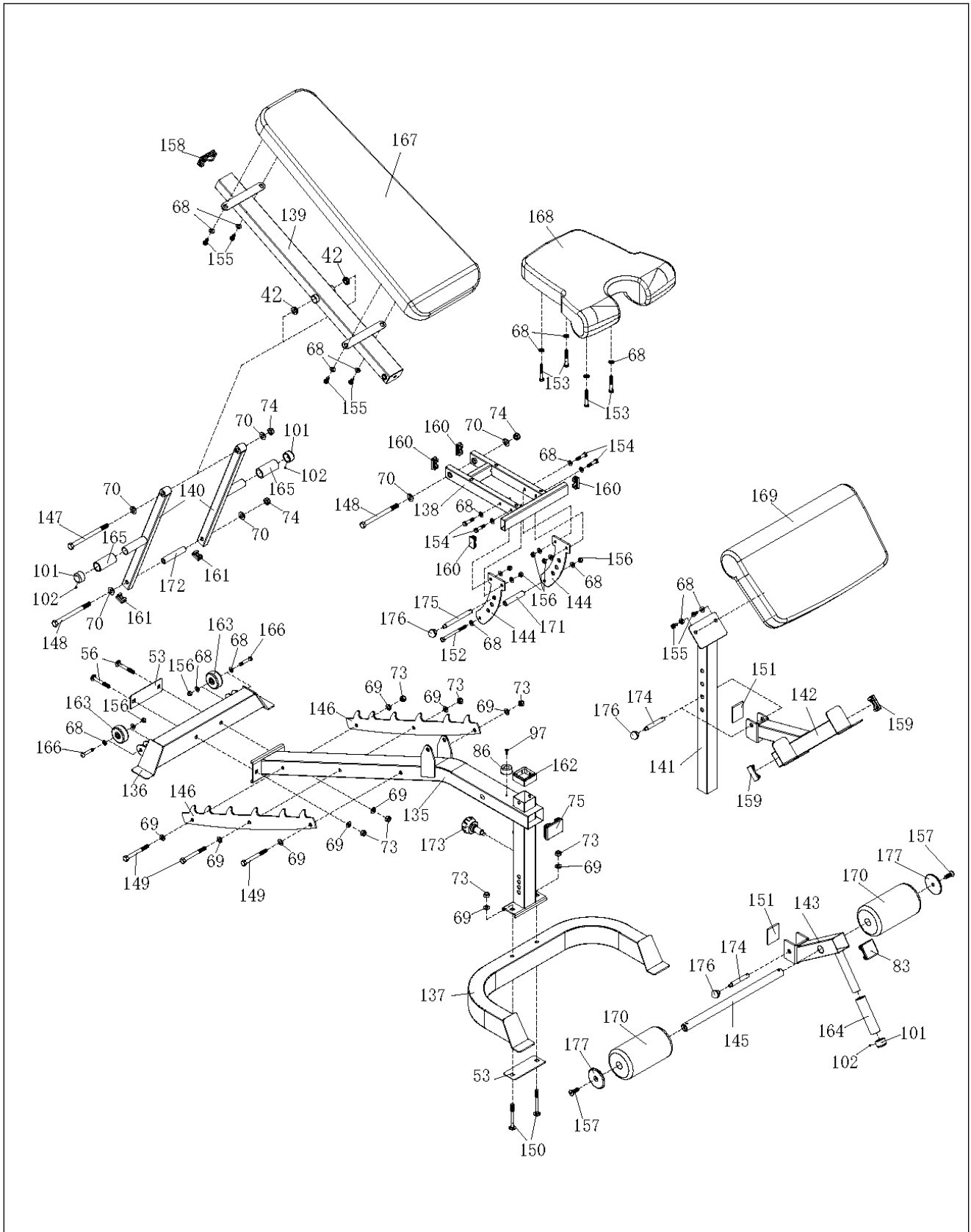

IMPEX[®] INC.

LIMITED WARRANTY

IMPEX Inc. ("IMPEX[®]") warrants this product to be free from defects in workmanship and material, under normal use and service conditions, for a period of two years on the Frame from the date of purchase. This warranty extends only to the original purchaser. IMPEX's obligation under this Warranty is limited to replacing or repairing, at IMPEX's option.

All returns must be pre-authorized by IMPEX. Pre-authorization may be obtained by calling IMPEX Customer Service Department at 1-800-999-8899. All freights on products returned to IMPEX must be prepaid by the customer. This warranty does not extend to any product or damage to a product caused by or attributable to freight damage, abuse, misuse, improper or abnormal usage or repairs not provided by an IMPEX authorized service centre or for products used for commercial or rental purposes. No other warranty beyond that specifically set forth above is authorized by IMPEX.

IMPEX is not responsible or liable for indirect, special or consequential damages arising out of or in connection with the use or performance of the product or other damages with respect to any economic loss, loss of property, loss of revenues or profits, loss of enjoyments or use, costs of removal, installation or other consequential damages of whatsoever natures. Some States do not allow the exclusion or limitation of incidental or consequential damages. Accordingly, the above limitation may not apply to you.

The warranty extended hereunder is in lieu of any and all other warranties and any implied warranties of merchantability or fitness for a particular purpose is limited in its scope and duration to the terms set forth herein. Some States do not allow limitations on how long an implied warranty lasts. Accordingly, the above limitation may not apply to you.

This warranty gives you specific legal right. You may also have other rights which vary from State to State.

Register online at www.marcypro.com.

IMPEX[®] INC.
2801 S. Towne Ave.
Pomona, CA 91766

ORDERING REPLACEMENT PARTS

Replacement parts can be ordered by calling our Customer Service Department toll-free at **1-800-999-8899** during our regular business hours: Monday through Friday, 9 a.m. to 5 p.m. Pacific standard time.

support@impex-fitness.com

When ordering replacement parts, always give the following information.

1. Model
2. Description of Parts
3. Part Number
4. Date of Purchase